

Tug Fenders

W TYPE FENDER (HWF)

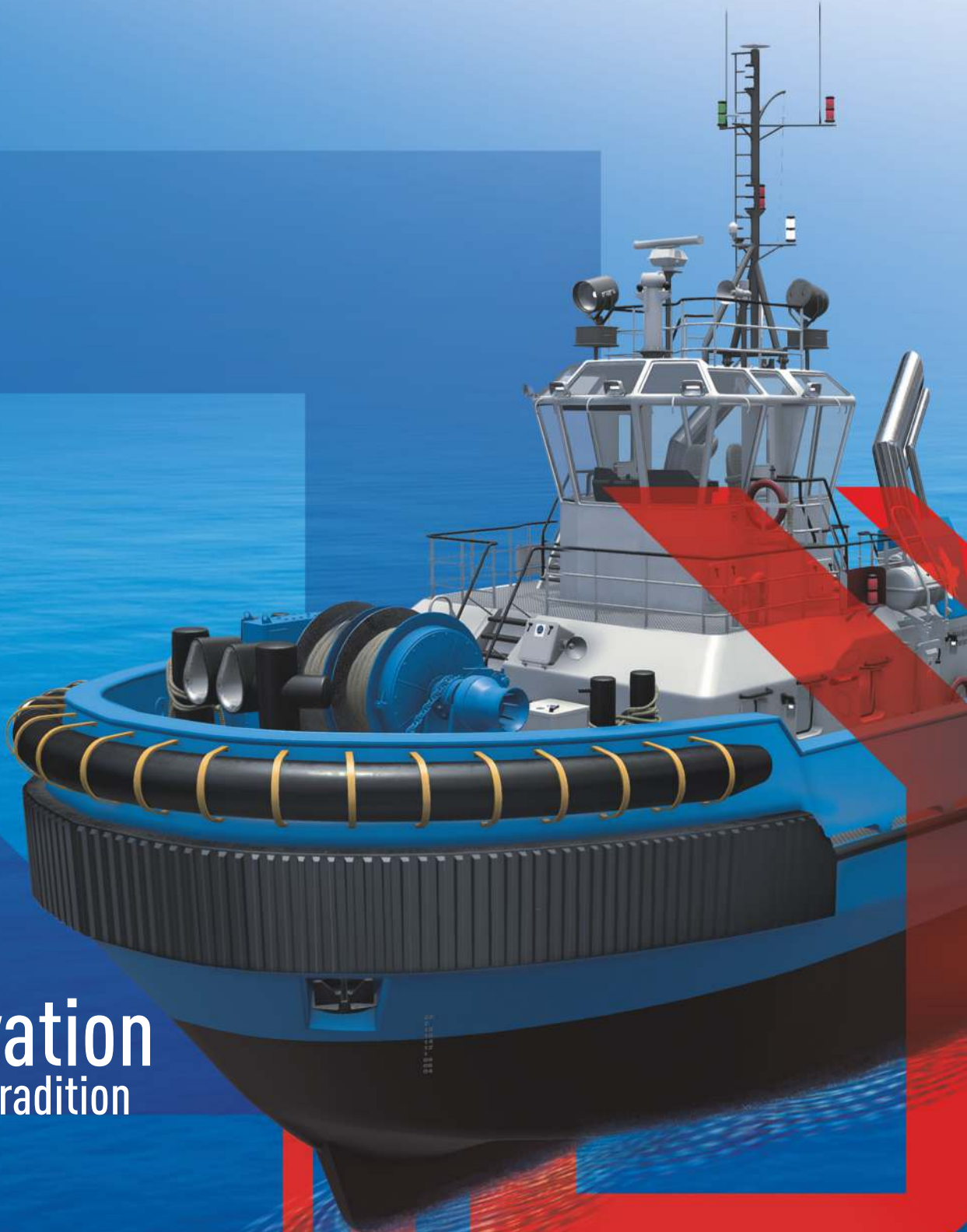

Where
Innovation
is Tradition



W TYPE FENDER (HWF)

W Type Fender are made for the most extreme operating conditions. The W-fender is one of the most successful fenders for tugs in the world today.

W Type Fender has a unique 'open bore' design which makes installation very simple. The flexible legs allow W-fenders to be curved around most hull shapes.

FEATURES

- Extreme-Duty Design
- Twin-Leg Attachment
- Open Bore for Easy Installation
- Grooved for Extra Grip
- Fits Around Tight Bends

APPLICATIONS

- All Types of Tugs
- Ocean-Going Tugs
- Icebreakers
- Large Harbour Tugs
- Bridge and Pile Protection

W TYPE FENDER (HWF)

DIMENSIONS

TYPE	A	B	C	D	E	F	K	L _{max}	WEIGHT
W32-20	320	200	280	180	100	67	50	2900	51
W40-25	400	250	350	220	110	75	55	2000	81
W48-30	480	300	426	269	135	90	65	3000	120
W50-45	500	450	420	255	90	100	75	2000	180

[Units: mm, kg/m]

FIXING

PIN	FLAT BAR	R _{min}
Ø25	100 x 20	600
Ø30	120 x 20	800
Ø40	140 x 20	900
Ø40	150 x 20	1000

[Units: mm]

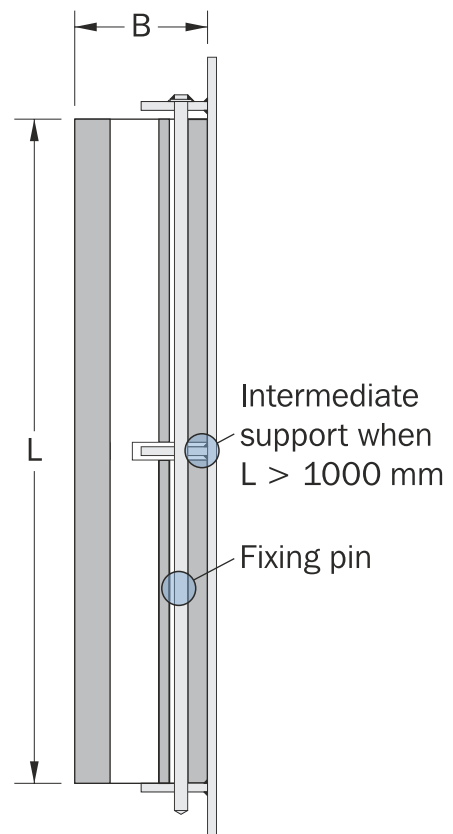

PERFORMANCE GRAPH

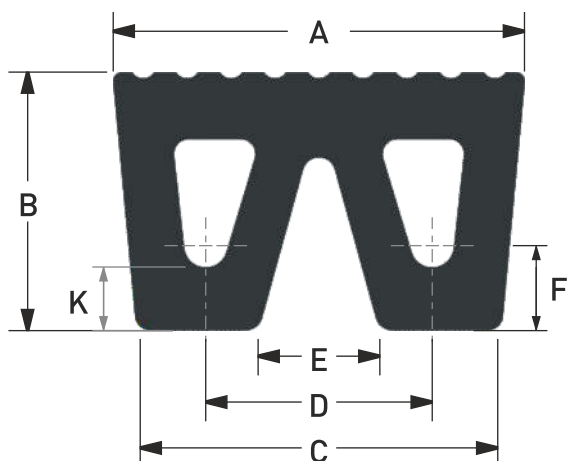
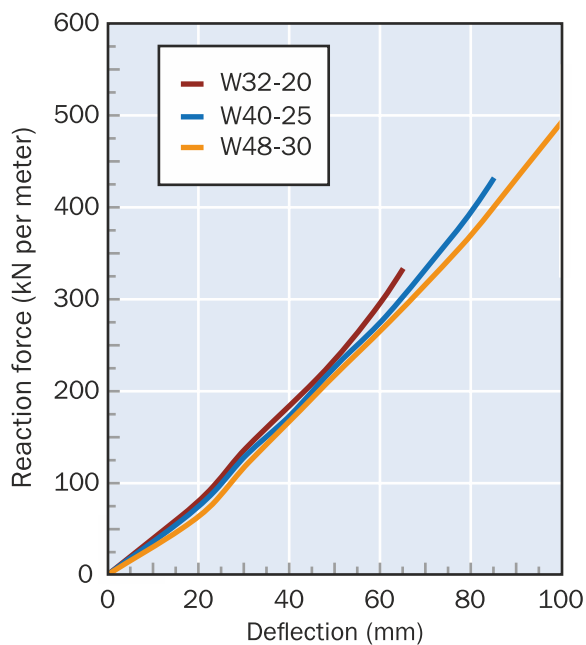



HI-TECH ELASTOMERS LTD.

WHERE INNOVATION IS A TRADITION

OFFICE

227, Hitech Elastomers, Santej-Vadsar Road,
Gandhinagar, Gujarat, INDIA - 384004.

Phone : +91-9824 654 671

Email : vpsales@hitechelastomers.com
sales1@hitechelastomers.com
sales@hitechelastomers.com

MANUFACTURING PLANT I:

798, Sola-Kalol Highway, Rakanpur,
Dist.: Gandhinagar, Gujarat, INDIA - 384002.

MANUFACTURING PLANT II:

227, Santej-Vadsar Road, Santej,
Dist. Gandhinagar, Gujarat, INDIA - 384004.

www.hitechelastomers.com